

BLANIK L-13 N82756

Weight and Balance

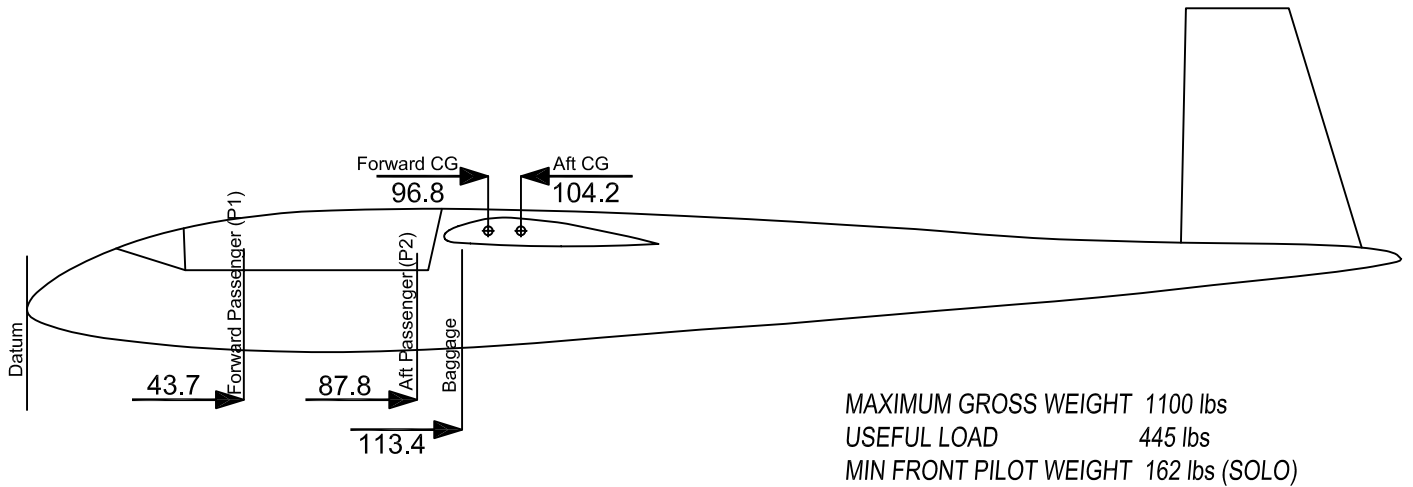

MAXIMUM GROSS WEIGHT 1100 lbs
 USEFUL LOAD 445 lbs
 MIN FRONT PILOT WEIGHT 162 lbs (SOLO)

	WEIGHT (lb)	x	ARM (in)	=	MOMENT
Sailplane Empty Weight	655		119.18		78062.9 in-lb
Front Pilot	_____		43.7		_____
Rear Pilot	_____		87.8		_____
Baggage	_____		113.4		_____
Total Weight	_____			Total Moment	_____

$$\frac{\text{Total Moment}}{\text{Total Weight}} = \text{_____} = \text{_____} \text{ Actual Flying CG}$$

Does actual CG fall within the range of 96.8 to 104.2?

Is total weight less than 1,100 lbs?

HAPPY FLYING